



UNIVERSITY OF CAMBRIDGE INTERNATIONAL EXAMINATIONS
General Certificate of Education Ordinary Level

CANDIDATE
NAME

CENTRE
NUMBER

--	--	--	--	--

CANDIDATE
NUMBER

--	--	--	--

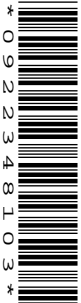

PHYSICS

5054/02

Paper 2 Theory

May/June 2009

1 hour 45 minutes

Candidates answer on the Question Paper.

Additional Materials: Answer Booklet/Paper

READ THESE INSTRUCTIONS FIRST

Write your Centre number, candidate number and name on all the work you hand in.
Write in dark blue or black pen.
You may use a soft pencil for any diagrams, graphs or rough working.
Do not use staples, paper clips, highlighters, glue or correction fluid.
DO **NOT** WRITE IN ANY BARCODES.

Section A

Answer **all** questions.
Write your answers in the spaces provided on the Question Paper.

Section B

Answer any **two** questions.
Write your answers on the lined pages provided and, if necessary, continue on the separate answer paper provided.

At the end of the examination, fasten all your work securely together.
The number of marks is given in brackets [] at the end of each question or part question.

For Examiner's Use	
Section A	
Q9	
Q10	
Q11	
Total	

This document consists of **16** printed pages.



Section A

Answer **all** the questions in this section.

- 1 A piece of paper falls from 4.0 m above the ground.
Fig. 1.1 shows how the height h above the ground varies with the time t .

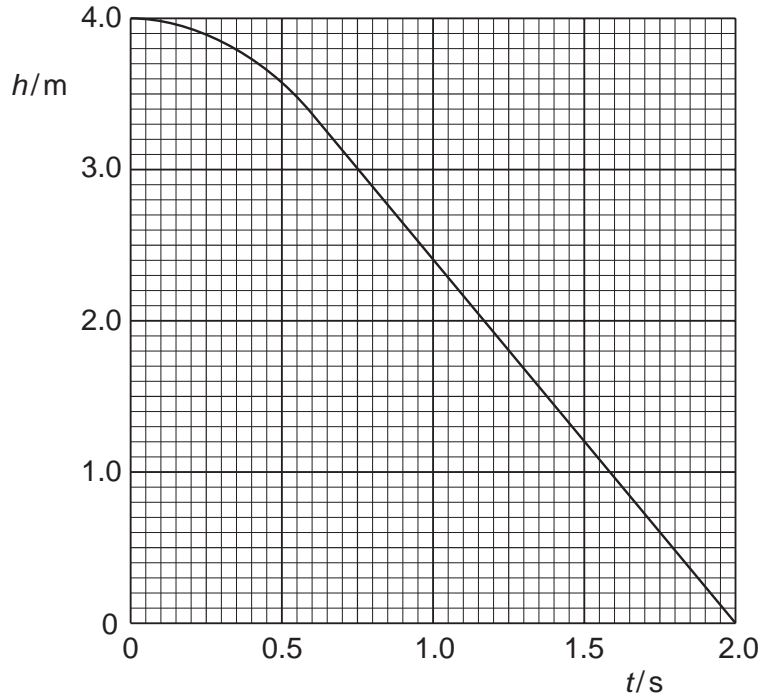

Fig. 1.1

- (a) State what happens to the speed of the paper as it falls.

.....
.....
..... [2]

- (b) Calculate the speed of the paper at time $t = 1.5$ s.

speed = [2]

- (c) As the paper falls, energy changes from one form to another.
State the main energy change between $t = 1.0$ s and $t = 2.0$ s.

.....
.....

2 Fig. 2.1 shows a metal pan containing water on a cooker. The hotplate heats the water.

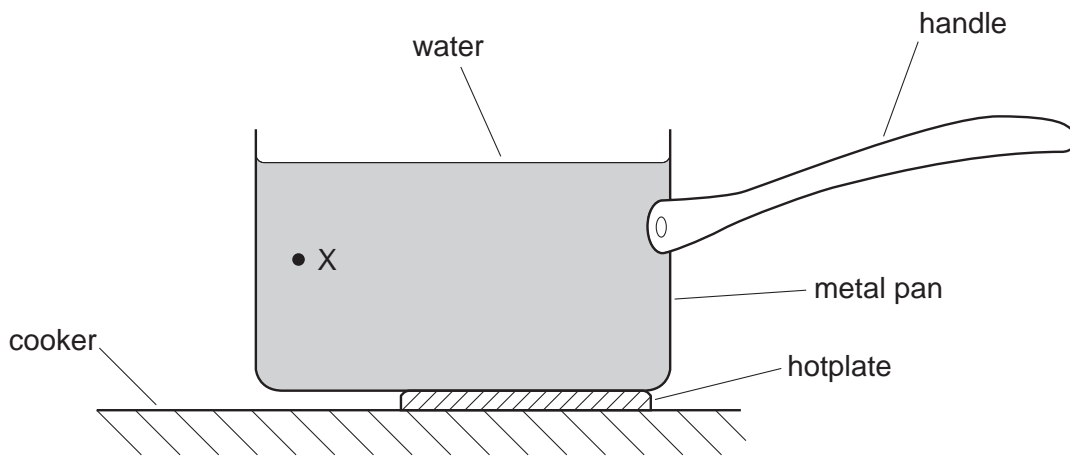

Fig. 2.1

- (a) (i) State the method of heat transfer through the metal pan.
 [1]
- (ii) Describe how the molecules transfer heat through the metal pan.

 [1]
- (b) (i) On Fig. 2.1, draw an arrow to show the direction of movement of the water at point X.
 [1]
- (ii) Explain why the water moves in this direction.

 [3]

- 3 Fig. 3.1 shows apparatus to measure the specific latent heat of fusion of water. In this question, you may ignore heat transfer to the ice from the room.

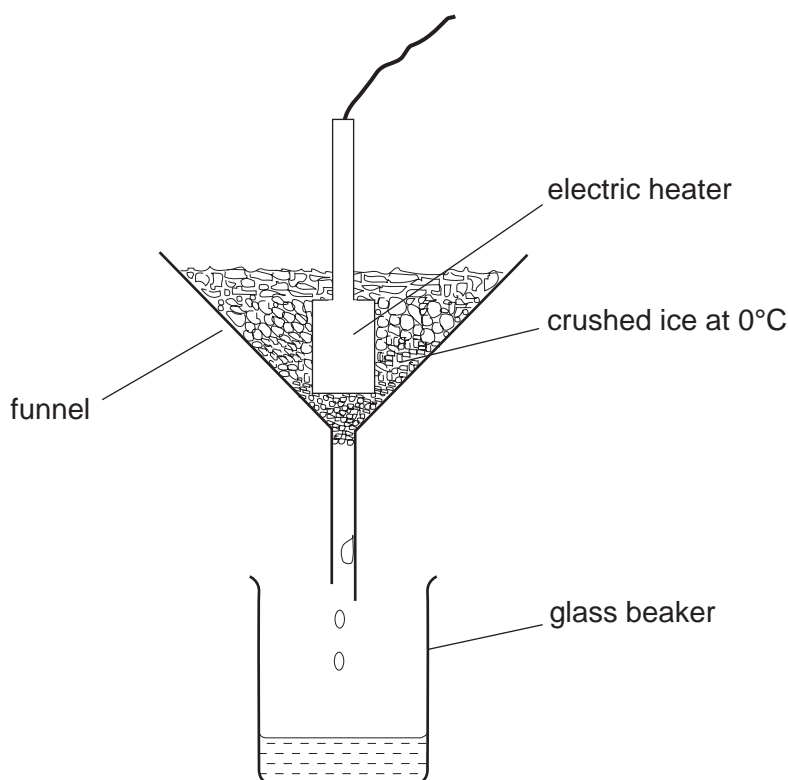

Fig. 3.1

The heater is switched on and water drips into the beaker at a constant rate. In 2.0 minutes, 31 g of water drips into the beaker. The power of the heater is 85 W.

- (a) Calculate the amount of electrical energy supplied to the heater in 2.0 minutes.

energy = [2]

- (b) Use your answer to (a) to calculate the specific latent heat of fusion of water.

specific latent heat = [2]

- (c) In another experiment using the same heater, ice colder than 0°C is used. State why less water drips into the beaker in 2.0 minutes.

.....

4 Fig. 4.1 shows the arrangement of molecules in a solid and in a liquid.

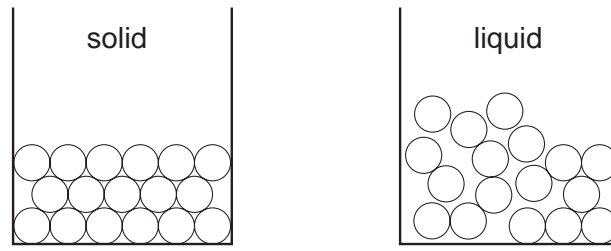

Fig. 4.1

(a) State one difference between the two arrangements.

.....

 [1]

(b) By writing about the forces between molecules and the motion of molecules, explain why

(i) the molecules of a solid and of a liquid have different arrangements,

.....
 [1]

(ii) the evaporation of a liquid cools the liquid,

.....

 [2]

(iii) the rate of evaporation is greater when a liquid is hotter.

.....

 [2]

- 5 Fig. 5.1 shows a man looking at his reflection in a rectangular plane mirror.

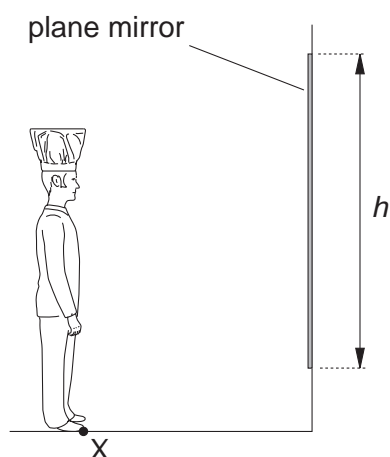

Fig. 5.1

The vertical side of the mirror has length h .

- (a) (i) On Fig. 5.1, draw a ray of light from point X that is reflected by the mirror to the man's eye. [1]
- (ii) On Fig. 5.1, mark the angle of incidence of your ray at the mirror. Label this angle i . [1]
- (iii) Define the *angle of incidence*.

..... [1]

- (b) On Fig. 5.1, draw a ray of light from the top of the man's hat that is reflected by the mirror to his eye.

Use your rays to determine the smallest value of h that allows the man to see all of the image in the mirror, from the top of his hat to his toes.

On the diagram, 1 cm represents 0.5 m.

$h = \dots\dots\dots$ [2]

6 Fig. 6.1 shows how ultrasound is used to produce an image of the heart.

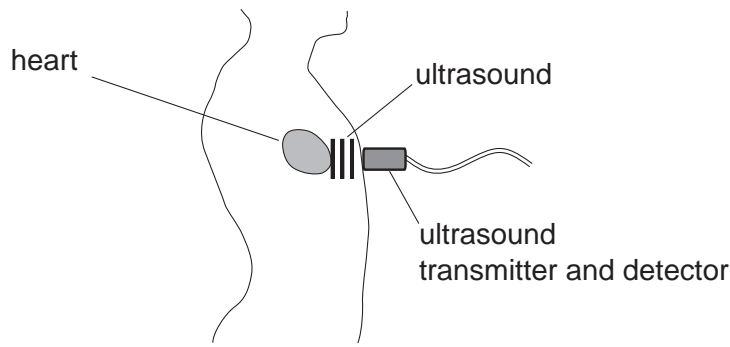

Fig. 6.1

(a) Define *ultrasound*.

.....
 [1]

(b) The ultrasound has a wavelength of 1.2×10^{-3} m. The speed of the ultrasound in the human body is 1500 m/s.

Calculate the frequency of the ultrasound.

frequency = [2]

(c) Ultrasound is a longitudinal wave.
 Describe how particles in the body move as the ultrasound passes.

You may draw a diagram if you wish.

.....

 [2]

(d) There are small bubbles of gas in the body.
 Explain why these bubbles expand and contract as the ultrasound passes.

.....

7 Fig. 7.1 shows two pieces of soft iron in the magnetic field of a strong permanent magnet

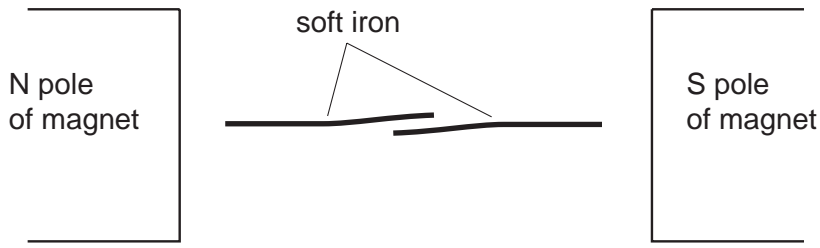

Fig. 7.1

The pieces of soft iron become magnetised.

(a) On Fig. 7.1, mark the magnetic poles produced at each end of both pieces of soft iron. [1]

(b) Fig. 7.2 shows a reed switch.

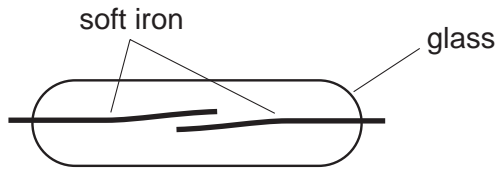

Fig. 7.2

The reed switch is placed between the poles of the strong permanent magnet. State and explain what happens.

.....

.....

..... [2]

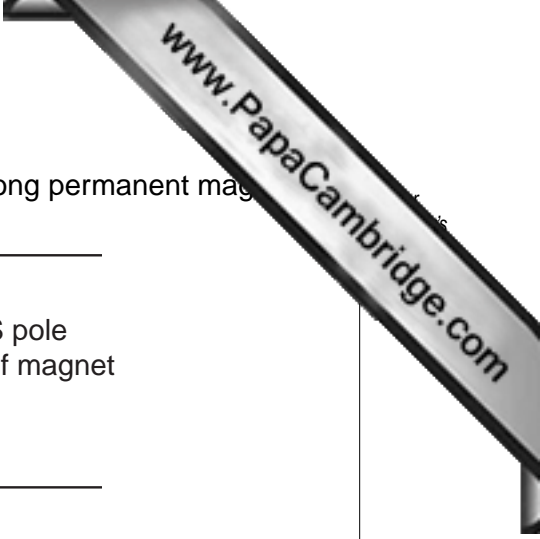

(c) Fig. 7.3 shows two separate electrical circuits.

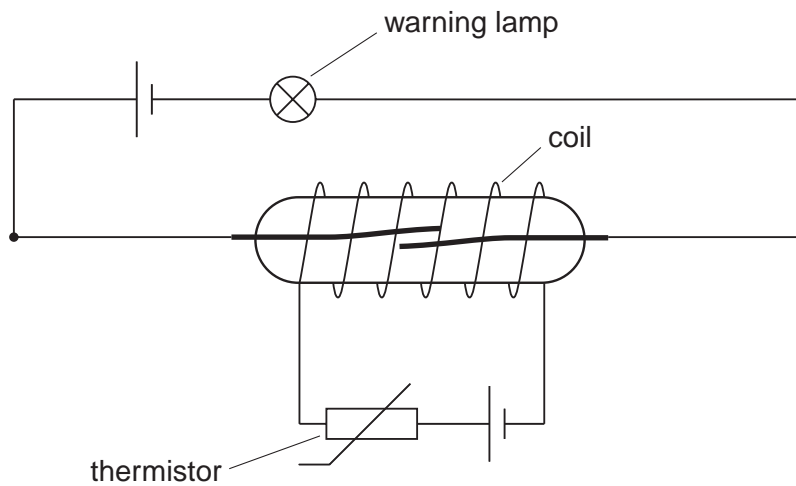

Fig. 7.3

One circuit consists of a reed switch, a cell and a warning lamp. The other circuit consists of a thermistor, another cell, and a coil wound round the reed switch. The thermistor is at the same temperature as the air around it.

(i) State what happens to the thermistor when the temperature of the air rises.

..... [1]

(ii) Explain why the warning lamp lights up when the air temperature rises.

.....

 [2]

- 8 The symbol ${}_{92}^{238}\text{U}$ represents a nucleus of uranium with nucleon number (mass number) 238 and proton number (atomic number) 92.

(a) State the meaning of *nucleon number*.

.....
.....
..... [2]

- (b) A nucleus of uranium-238 decays to form a nucleus of thorium by the emission of an alpha-particle.

State

(i) the proton number of an alpha-particle,

..... [1]

(ii) the nucleon number of an alpha-particle,

..... [1]

(iii) the proton number of thorium,

.....

(iv) the nucleon number of the thorium isotope formed.

..... [1]

Section B

Answer **two** questions from this section.

Use the lined pages provided and, if necessary, continue on the separate sheets available from the Supervisor.

- 9 (a) A lamp is marked 24V, 100W. Describe an experiment to check that the electrical power supplied to the lamp is 100W when the potential difference (p.d.) across it is 24V. In your account you should
- include a circuit diagram,
 - state the readings that are taken,
 - show how the result is calculated from the readings.
- [4]
- (b) Two lamps are connected in parallel to a 240V mains supply, as shown in Fig. 9.1.

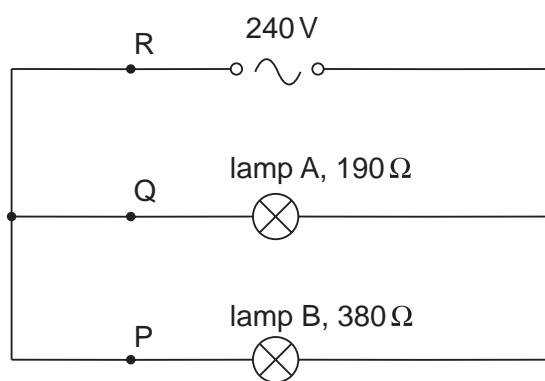

Fig. 9.1

Lamp A has a resistance of $190\ \Omega$ and lamp B has a resistance of $380\ \Omega$.

- (i) Calculate the current at points P, Q and R. [3]
- (ii) Calculate the total resistance of the circuit. [2]
- (c) Fig. 9.2 shows the same lamps connected in series to the mains supply.

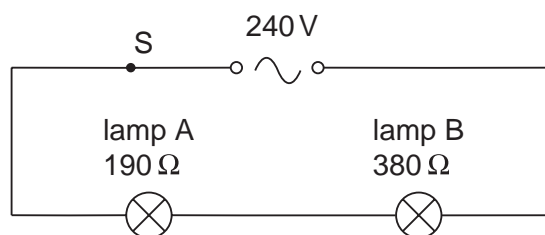

Fig. 9.2

- (i) Calculate the current at point S. [2]
- (ii) Calculate the p.d. across lamp A. [1]
- (d) In a house, all lamps are connected in parallel to the mains supply, not in series. State and explain two reasons for this.
- In your explanation you may refer to the results of your calculations in (b) and (c). [3]

10 Fig. 10.1 shows the horizontal forces as a cyclist travels forwards.

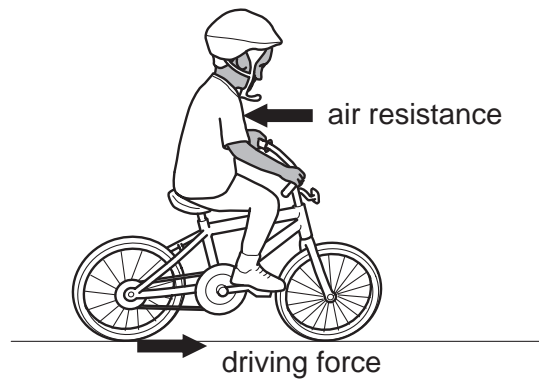

Fig. 10.1

The cyclist produces the driving force that acts on the back wheel. In this question, you may ignore any frictional force acting on the front wheel.

- (a) The bicycle accelerates until a constant speed is reached.
- Describe how the size of the air resistance changes during this time. [2]
 - Compare the sizes of the two horizontal forces when the bicycle is accelerating. [1]
- (b) The total mass of the bicycle and the cyclist is 75 kg. At one instant, the speed of the bicycle is 4.0 m/s, the driving force is 30 N and the air resistance is 20 N.

Calculate

- the total kinetic energy of the bicycle and the cyclist, [3]
 - the acceleration of the bicycle and the cyclist. [2]
- (c) As the bicycle moves, energy is transmitted from the pedals to the back wheel.

Fig. 10.2 shows what happens to the energy input to the pedals.

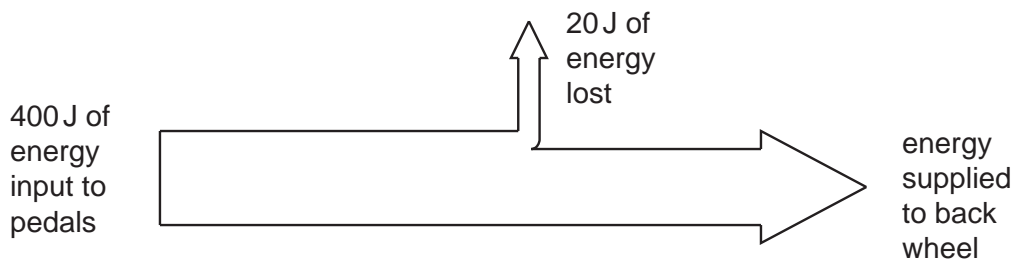

Fig. 10.2

- As energy is transmitted to the back wheel, some is lost. Explain how this happens. [2]
 - Calculate the efficiency of the bicycle in transmitting energy from the pedals to the back wheel. [2]
- (d) Some bicycles are made from low density materials. Explain why this is an advantage. [3]

11 An a.c. generator produces alternating current.

- (a) (i) Draw a labelled diagram of a simple a.c. generator.
 (ii) Explain how the current is generated.
- (b) The output of the generator is connected to the terminals of a cathode-ray oscilloscope. Fig. 11.1 shows the trace produced on the screen of the oscilloscope.

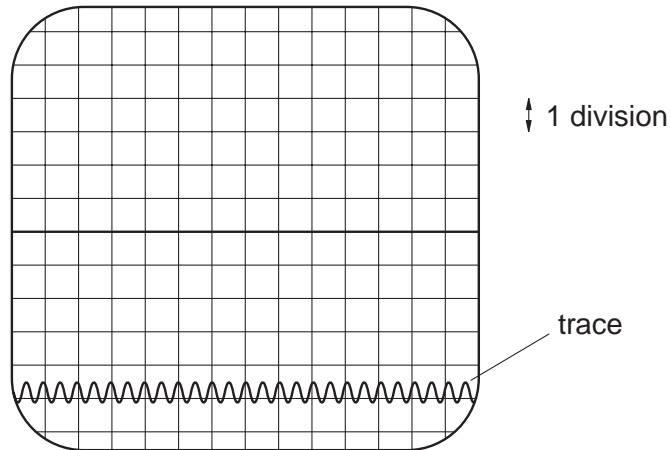

Fig. 11.1

- (i) Each vertical division on the scale in Fig. 11.1 represents 2 volts.
 Describe how you would check that one vertical division represents 2 volts. [4]
- (ii) The trace in Fig. 11.1 is too small and is at the bottom of the screen.
 Adjustments are made to the oscilloscope controls to produce the trace in Fig. 11.2.

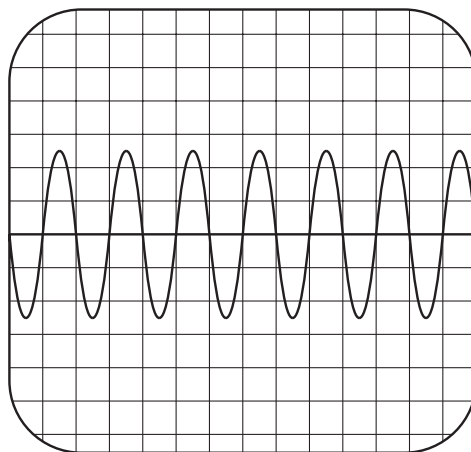
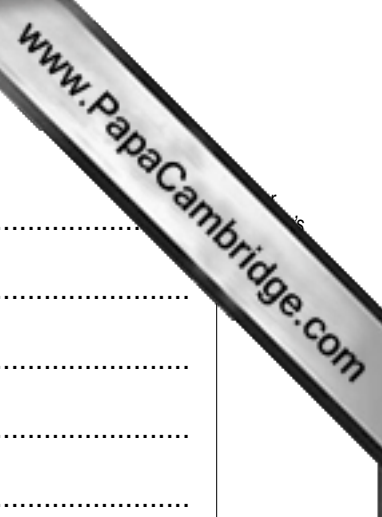

Fig. 11.2

- State and explain the adjustments made to the oscilloscope controls. [3]
- (iii) Explain how the beam of electrons is produced inside the cathode-ray oscilloscope. [3]

A series of horizontal dotted lines for writing, spanning the width of the page.

A series of horizontal dotted lines for writing, spanning the width of the page.



A series of horizontal dotted lines spanning the width of the page, intended for writing answers.

Permission to reproduce items where third-party owned material protected by copyright is included has been sought and cleared where possible. Every reasonable effort has been made by the publisher (UCLES) to trace copyright holders, but if any items requiring clearance have unwittingly been included, the publisher will be pleased to make amends at the earliest possible opportunity.

University of Cambridge International Examinations is part of the Cambridge Assessment Group. Cambridge Assessment is the brand name of University of Cambridge Local Examinations Syndicate (UCLES), which is itself a department of the University of Cambridge.